

REV.	ECN NO OR DESCRIPTION	REVISED	DATE
A	PDR RELEASE	AMYC	2008.12.16

- SPECIFICATIONS:
1. OTHER GENERAL SPEC. TO REFER "2CA1506 SERIES SPEC".
 2. TO CONFORM TO SINGATRON HAZARDOUS SUBSTANCE FREE SPEC.
 3. GREEN PRODUCT IDENTIFICATION LABEL ON PACKAGING: **G.P. PASS**
 4. PLEASE REFER TO TABLE 1 FOR TERMINAL LENGTH. TABLE 1
 5. PACKAGE: SEE "2CA1508 SERIES" PACKAGE

PART NO.
2CA1508-000111

PACKAGE
1: TRAY
HOUSING COLOR
1: BLACK
CONTACT PLATING
1: Au / TIN

" TABLE 1 "

PIN TYPE	DIM.L±0.20	PIN NUMBER
DETECT	3.50 mm	36, 67
GENERAL	4.25 mm	THE REST
POWER	5.00 mm	1, 17, 34, 35, 51, 68

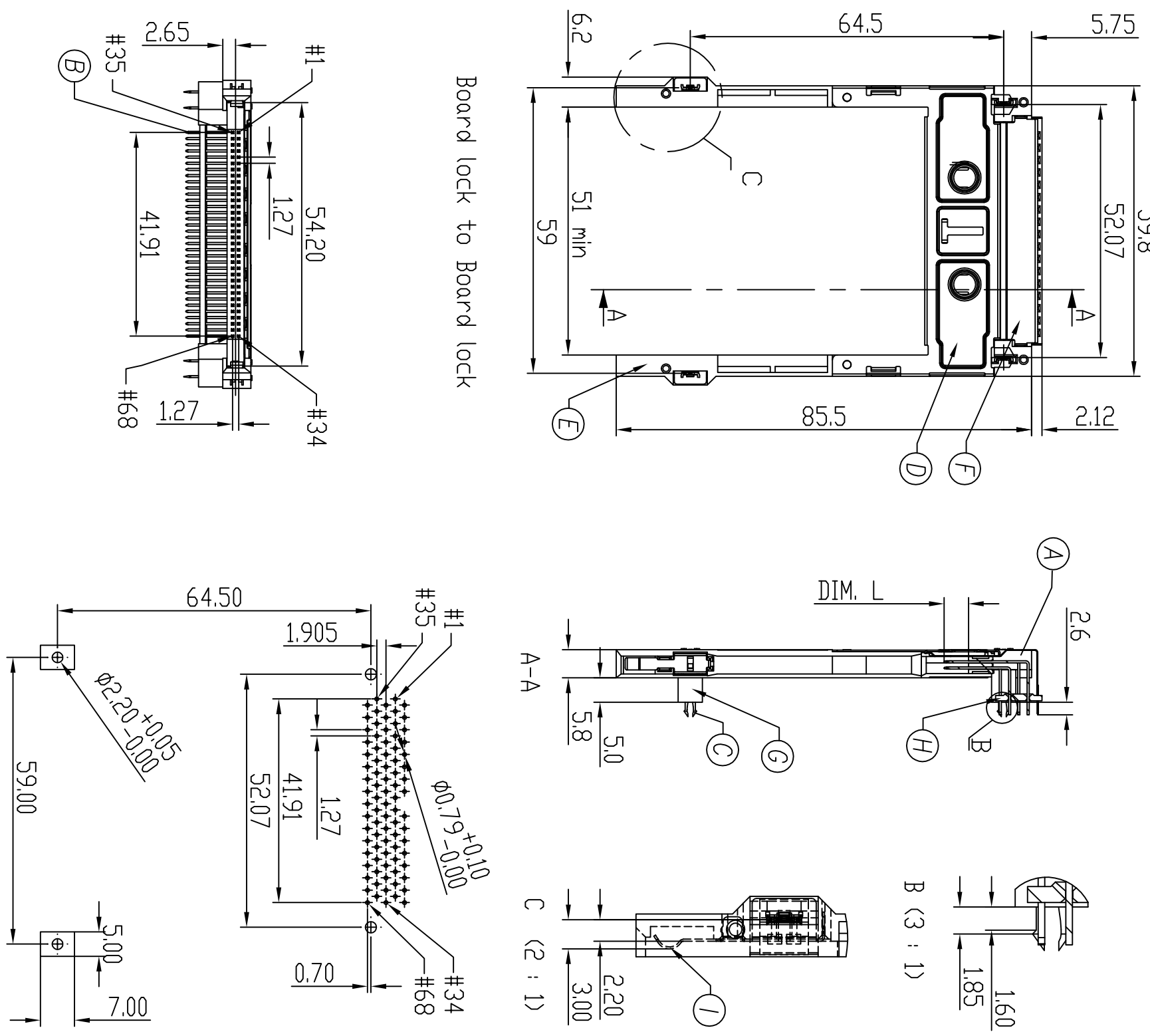

Recommend PCB Layout
Tolerance: ±0.05mm (Top view)
Recommend PCB THICKNESS: 1.6mm

I	SIDE CONTACT	2	PHOSPHOR BRONZE	NI PLATING
H	LOCATOR	2	PBT+G.F30%(UL94V-0)	BLACK COLOR
G	STAND OFF	2	PBT+G.F30%(UL94V-0)	BLACK COLOR
F	CARD BUS SHEEL	2	PHOSPHOR BRONZE	AU PLATING
E	RAIL	2	PBT+G.F30%(UL94V-0)	BLACK COLOR
D	TOP COVER	2	STAINLESS STEEL	
C	HOOK PIN	2	PHOSPHOR BRONZE	TIN PLATING
B	Contact	68	COPPER ALLOY	Au / TIN PLATING
A	BASE	1	PBT+G.F30%(UL94V-0)	BLACK COLOR
NO	DESCRIPTION	QTY	MATERIAL	PLATING & COLOR

Singatron Enterprise Co., Ltd.
信音企業股份有限公司

DECIMALS:	ANGLES:	TITLE	68 PIN CAED BUS 5mm TYPE
X :±0.5	X :±2°	DWN	Amc 2008.12.16
X.X :±0.3	X.X :±1°	CHKD	Johnson 2008.12.16
X.XX :±0.2		APVD	Johnson 2008.12.16

PART NO. 2CA1508-000111

CUSTOMER COPY