

REV	ECN NO OR DESCRIPTION	REVISED	DATE
A	PDR RELEASE	AMNC	2009.07.09

- SPECIFICATIONS:
- OTHER GENERAL SPEC. TO REFER "2DS1544 SERIES SPEC".
 - TO CONFORM TO EU ROHS DIRECTIVE.
 - GREEN PRODUCT IDENTIFICATION LABEL ON PACKAGING: **ROHS**
 - PACKAGE: SEE "2DS1544 SERIES" PACKAGE.

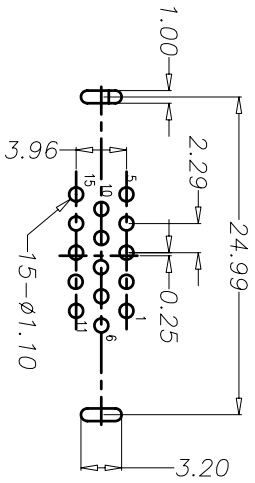

RECOMMEND PCB LAYOUT(TOP VIEW)
PCB THICKNESS:1.60±0.10mm.
TOLERANCE:±0.05mm.

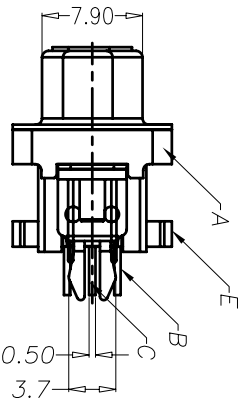
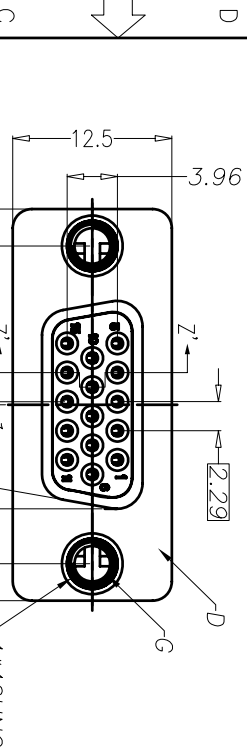
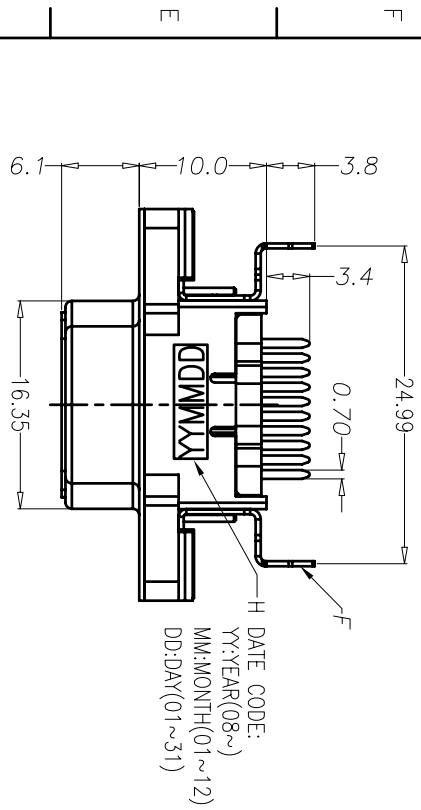
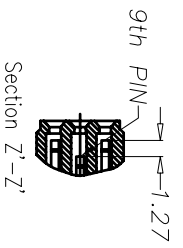

PART NO.
2DS1544-001121

- PACKAGE
- 1: TRAY
- HOUSING COLOR
- 2: BLUE
- CONTACT PLATING
- 1: Au G.F PLATING
- COVER COLOR
- 1: BLUE
- SCREW
- 0: 螺钉

H	Ink	1	Domino R-270BK & MC-270BK	BLACK
G	RIVET	2	COPPER ALLOY	NI PLATING
F	BOARD LOCK	2	SPCC T=0.40mm	TIN PLATING
E	COVER	1	PBT+30%G.F UL94V-0	SEE "PART NO."
D	SHELL	1	SPCC T=0.40mm	NI PLATING
C	SHORT9 CONTACT	5	PHOSPHOR BRONZE T=0.2mm	AU G.F PLATING
B	CONTACT	10	PHOSPHOR BRONZE T=0.2mm	AU G.F PLATING
A	HOUSING	1	PBT+30%G.F UL94V-0	SEE "PART NO."
NO	DESCRIPTION	QTY	MATERIAL	PLATING & COLOR
UNLESS OTHERWISE SPECIFIED TOLERANCES				
Singaton Enterprise Co., Ltd.				
TITLE: D-SUB 15P 10 HIGH LOW COST SHORT 9 ASSEMBLY				
DWG: AMC 20080708 PART NO. 2DS1544-001121				
CHKD: AMNC 20080708 SCALE: N/A UNIT: mm				
APVD: AMNC 20080708 SIZE: A3 SHEET: 1 OF 1 REV: A				
CUSTOMER COPY				