

VIEW WITH COVER

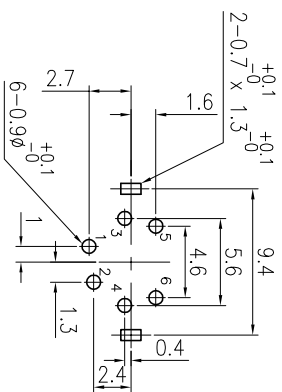

RECOMMENDED PCB LAYOUT
(BOTTOM VIEW)(TOL. ±0.05)

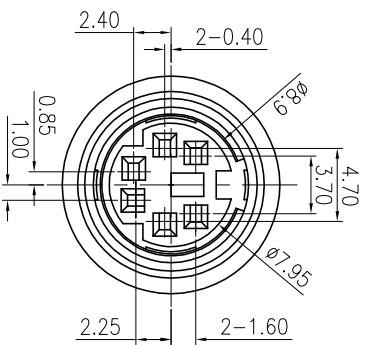
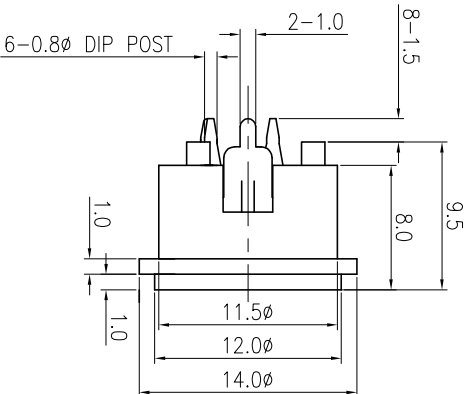
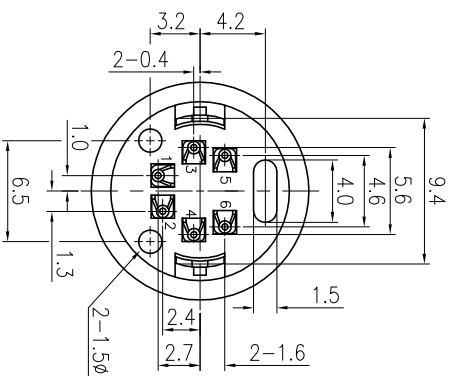
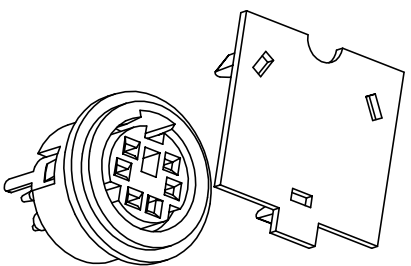
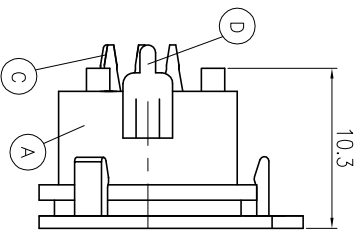

VIEW WITH COVER

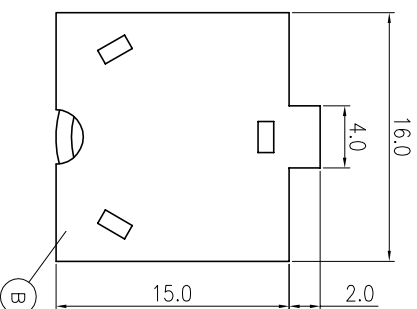

VIEW WITH COVER

- SPECIFICATIONS:
- CURRENT CARRYING CAPACITY: 1A 100VAC MAX. OR 2A 12VDC MAX.
 - CONTACT RESISTANCE: 30mΩ MAX.
 - INSULATION RESISTANCE: 100MΩ MIN. AT 250VDC
 - DIELECTRIC STRENGTH: 250VAC 1 MINUTE WITHOUT BREAKDOWN
 - INSERTION FORCE: 0.8KG ~ 5KG
 - WITHDRAWAL FORCE: 0.8KG ~ 4KG
 - SINGLE CONTACT MAINTENANCE FORCE: 20g MIN. (TEST PIN: 0.6φ)
 - CONTACT PULL STRENGTH: 1KG MIN.
 - LIFE CYCLE TEST: 5000 CYCLES, @ 10 TO 20 CYCLES PER MINUTE WITH NO ELECTRICAL LOAD
 - MOISTURE RESISTANCE TEST: 500 HOURS @90% TO 95%, @40C±2C
 - HEAT RESISTANCE TEST: 500 HOURS @100C±2C
 - OPERATION TEMPERATURE: -10C TO 60C
 - SOLDERABILITY TEST: DEWET PERCENTAGE 95% MIN. (LIMITED TO SILVER PLATING)
- TEST CONDITION:
- | SOLDER | FLUX | TEMPERATURE | DWELL TIME |
|-----------|--------------------------|-------------|---------------|
| Sn60/Pb40 | 25% BY WEIGHT OF ROSIN | 232C±5C | 5±0.5 SECONDS |
| | 75% BY WEIGHT OF ALCOHOL | | |
- SOLDERING HEAT TEST: @260C±10C FOR 10±0.5 SECONDS
 - SOLDERING CONDITION: WAVE SOLDERING.
 - TO CONFORM TO SINGATRON HAZARDOUS SUBSTANCE FREE SPEC
 - GREEN PRODUCT IDENTIFICATION MARK ON JACK
 - GREEN PRODUCT IDENTIFICATION LABEL ON PACKAGING: **G-P PASS**
 - D/C DESCRIPTION: YYMMDD



D	EARTH TERMINAL	1	BRASS 0.4T	Ni 60u"Min, OVER Cu 80u"Min.
C	CONTACTOR	6	COPPER ALLOY 0.2T	Ag 40u"Min, OVER Cu 60u"Min.
B	COVER	1	HI-TEMP THERMOPLASTIC, UL94V-0	BLACK COLOR
A	BODY	1	HI-TEMP THERMOPLASTIC, UL94V-0	BLACK COLOR
NO	DESCRIPTION	QTY	MATERIAL	PLATING & COLOR
UNLESS OTHERWISE SPECIFIED TOLERANCES				
Singatron Enterprise Co., Ltd. 信登企業股份有限公司				
TITLE: MINIATURE DIN CONNECTOR				
DWG	UNIT: mm	PART NO.	2MJ-0304-002	
CHKD	RYAN	SCALE	3:1	UNIT: mm
APVD	ROBIN	SIZE	A3	SHEET: 10F1
CUSTOMER COPY				

REV.	EGN NO OR DESCRIPTION	REVISED	DATE
A	PRODUCT RELEASE	JUNHUA	2008.08.26
B	1. REQUIRE IN ACCORDANCE WITH EGR CHANGE INTO MANNER OF PACKING OF 2MJ-0304-002 TAPE REEL PACK. 2. EGN NO. C080192-3/3.	JUNHUA	2008.11.14

1 2 3 4 5 6 7 8