

REV.	ECN NO OR DESCRIPTION	REVISED	DATE
A	PDR RELEASE	AMYC	2009.06.26

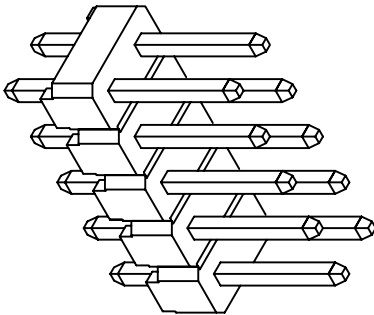

### S Type

- SPECIFICATIONS:
1. CURRENT RATING: 3 AMPS.
  2. INSULATOR RESISTANCE: 5000 Megohms Min.
  3. DIELECTRIC WITHSTANDING: AC 500V
  4. OPERATING TEMPERATURE: -40°C TO 105°C
  5. PACKING: SEE "2PH1527 SERIES" PACKAGE.
  6. HALOGEN FREE PRODUCT IDENTIFICATION LABEL ON PACKAGING:
  7. SOLDER HEAT RESISTANCE : 260°C. 10 SECS.
  8. SEE "2.54mm Pitch PIN HEADER SERIES SPEC"

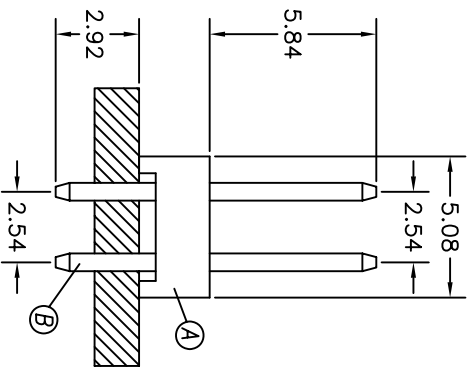
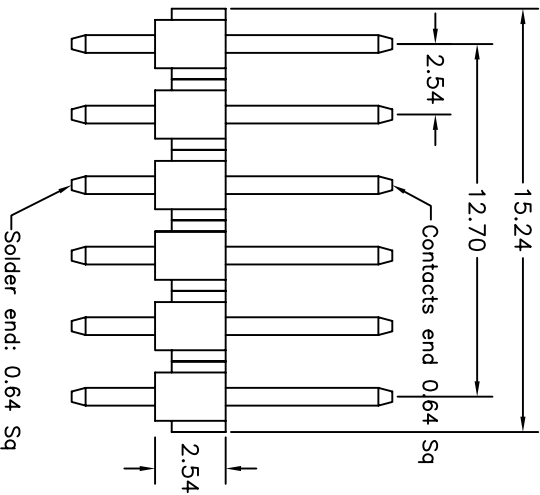
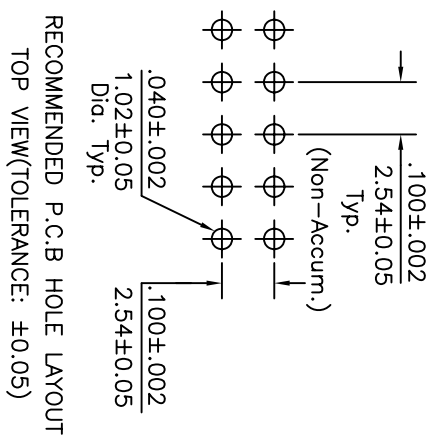

PART NO.  
2PH1527-000111

PACKAGE  
1: BAG  
HOUSING COLOR  
1: BLACK  
CONTACT PLATING  
1: GOLD FLASH

B	CONTACT	12	BRASS	GOLD FLASH
A	HOUSING	1	LCP	BLACK COLOR
NO	DESCRIPTION	QTY	MATERIAL	PLATING & COLOR
UNLESS OTHERWISE SPECIFIED TOLERANCES				
Singatron Enterprise Co., Ltd. 信晉企業股份有限公司				
DECIMALS:	ANGLES:	TITLE		
X : $\pm 0.5$	X : $\pm 2^\circ$	2.54mm(0.1") PIN HEADER		
X.X : $\pm 0.3$	X.X : $\pm 1^\circ$	DWN	AWC 2008.03	PART NO. 2PH1527-000111
X.XX : $\pm 0.2$		CHKD	JANSON 2008.08	SCALE:N/A
		APVD	JANSON 2008.08	SIZE: A3
				SHEET: 1 OF 1
				REV: A

CUSTOMER COPY