

REV	EGN NO	OR DESCRIPTION	REVISED	DATE
A	PDR RELEASE	LULU	2008.02.29	
B	EGR NO. L090030	AMYC	2009.06.04	

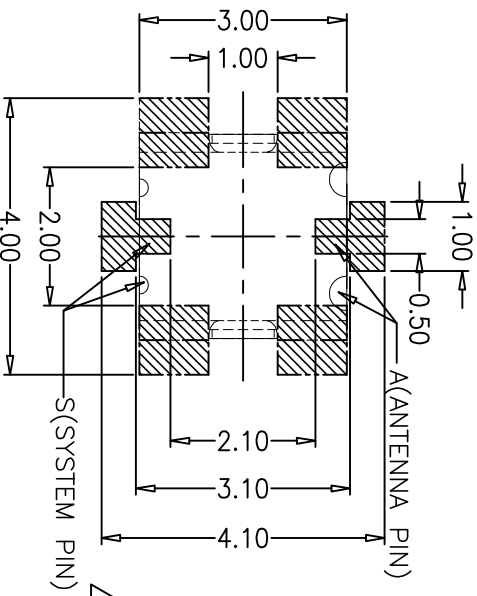
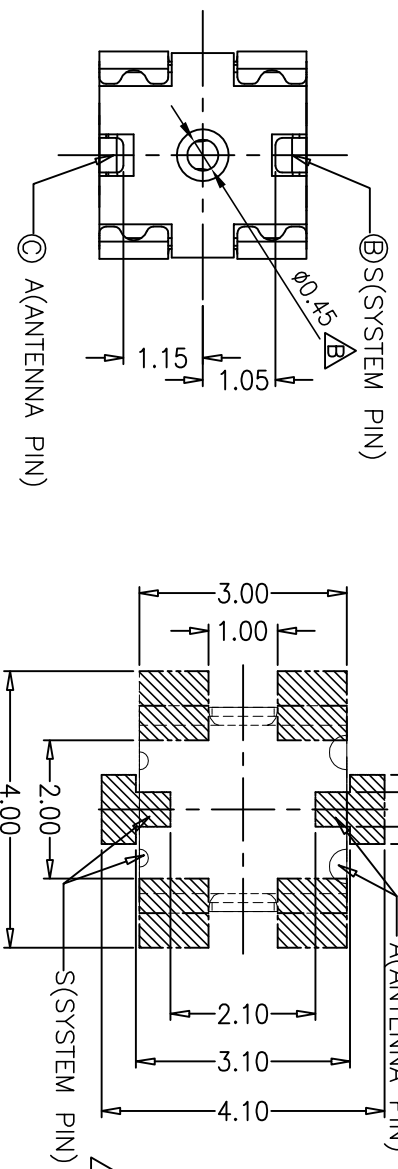
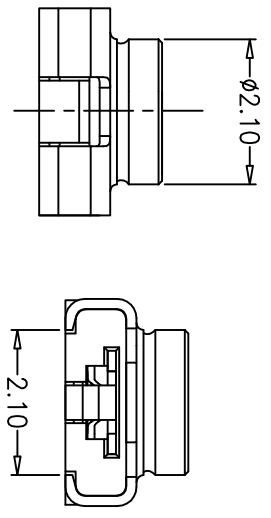
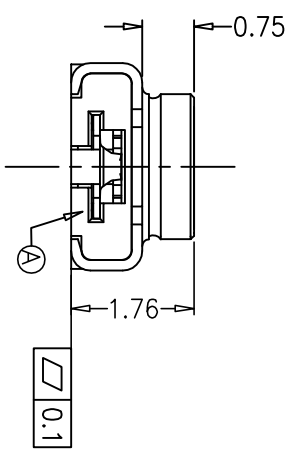
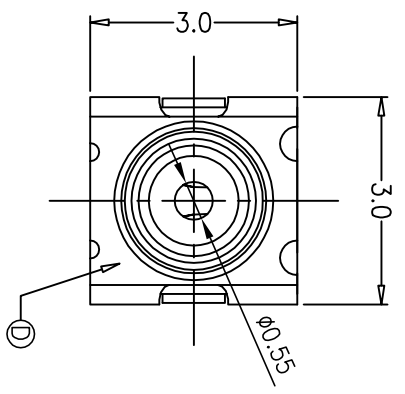
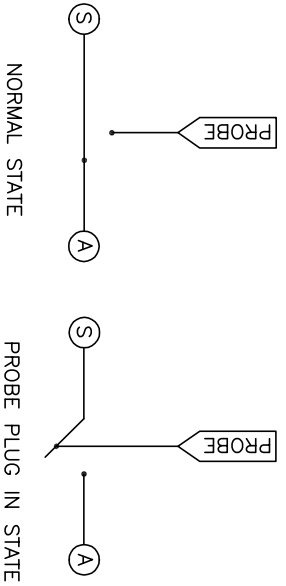
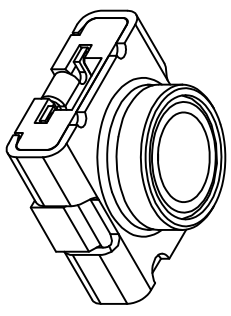

SPECIFICATIONS:

1. TO CONFORM TO THE "SINGATRON HSF SPECIFICATION"
2. GREEN PRODUCT IDENTIFICATION LABEL IN PACKING: **G.P. PASS**
3. SOLDER HEAT RESISTANCE : 260C 10 SECS.
4. SEE "2RF1500 SERIES" SPECIFICATION
5. PACKAGE : SEE "2RF1500 SERIES" SPECIFICATION

PART NO.

2RF1500-000111

PACKAGE & REEL
1: TAPE & REEL
HOUSING COLOR
1: BLACK COLOR
CONTACT PLATING
1: Au PLATING

NO	DESCRIPTION	QTY	MATERIAL	PLATING & COLOR
D	SHIELD	1	BRASS C2680	AU PLATING
C	CONTACT A	1	Ti-Cu	AU PLATING
B	CONTACT S	1	PBS C5191	AU PLATING
A	HOUSING	1	LCP	BLACK COLOR

UNLESS OTHERWISE SPECIFIED TOLERANCES

RECOMMENDED PADS LAYOUT

<TOP VIEW>

NOTE : TOLERANCE FOR PCB LAYOUT IS ± 0.05

DECIMALS:	ANGLES:	TITLE
X :±0.5	X :±2°	TITLE SWITCHABLE RECEPTACLE CONNECTOR H=0.75
X.X :±0.3	X.X :±1°	DRAWN AMC 2008/02/03 PART NO. 2RF1500-000111
X.XX :±0.2		CHKD LANSON 2008/02/03 SCALE:EN/A UNIT: mm
		APVD LANSON 2008/02/03 SIZE: A3 SHEET: 1 OF 1 REV: B

CUSTOMER COPY

Singatron Enterprise Co., Ltd.
信譽企業股份有限公司