

REV.	ECN NO OR DESCRIPTION	REVISED	DATE
A	PDR NO.:C100121-2A	Shawn	2010.09.27
B	EVN NO.:S101246	Shawn	2010.12.28

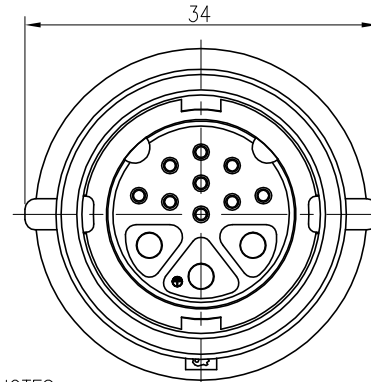

NOTES:

1. WATERPROOF RATE: IP67(WHEN PROPERLY MATED)
IP67: IMMERSED IN 1M WATER FOR 30 MINUTES
2. TEST CONDITIONS:
 - 2-1. CONTACT RESISTANCE: 3 Ohm Max.
 - 2-2. HI-POT TEST 500VAC,5mA(1SEC)
 - 2-3. INSULATION RESISTANCE: 100M MIN. BY 500 VDC
 - 2-4. OTHER GENERAL SPEC. TO REFER "CIRCULAR SERIES SPEC".
3. TO CONFORM TO SINGATRON HAZARDOUS SUBSTANCE FREE SPEC.
4. GREEN PRODUCT IDENTIFICATION LABEL ON PACKAGING: **G.P. PASS**
5. FOR PANEL THICKNESS MAX OF 3.5mm

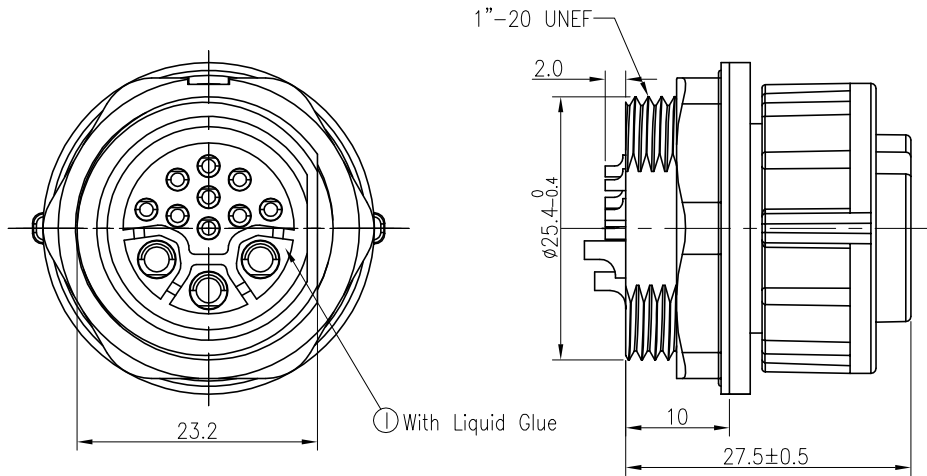
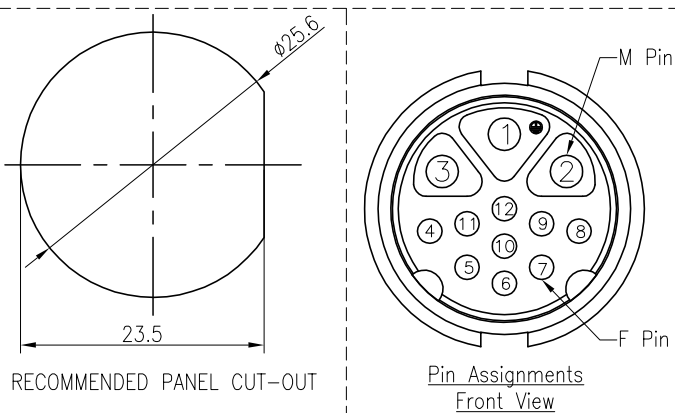
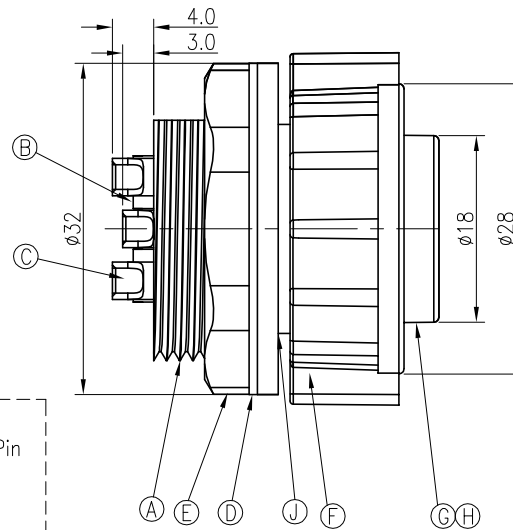

J	O-RING-2	1	EPDM	BLACK
I	LIQUID GLUE	1	N/A	BLACK
H	O-RING-1	1	EPDM	BLACK
G	BODY	1	NYLON+GF	BLACK
F	LOCK NUT	1	NYLON+GF	BLACK
E	SCREW NUT	1	NYLON+GF	BLACK
D	GASKET	1	EPDM	BLACK
C	MALE PIN	3	BRASS	GOLD FLASH OVER NICKEL PLATING
B	FEMALE PIN	9	Phosphor Bronze	6uin GOLD PLATING OVER NICKEL PLATING
A	HOUSING	1	NYLON+GF	BLACK
NO	DESCRIPTION	QTY	MATERIAL	PLATING & COLOR

UNLESS OTHERWISE SPECIFIED TOLERANCES

DECIMALS: X :±0.5
X.X :±0.3
X.XX :±0.2

ANGLES: X :±2°
X.X :±1°

Singatron Electronic(China) Co., Ltd.
信音電子(中國)股份有限公司

TITLE: CIRCULAR LARGE SIZE (SOLDER/LOCK TYPE)
FEMALE CONN. FEMALE 12PIN(5+20A)

DWN: Shawn PART NO.2CG3037-X12F00

CHKD: Steve SCALE 2:1 UNIT: mm

APVD: Quan SIZE: A3 SHEET: 1 OF 1 REV: B

CUSTOMER COPY