

REV.	ECN NO OR DESCRIPTION	REVISED	DATE
A	PDR NO.:T09012015L	Steve	2009.01.08
B	ECN NO:S130338	Harlen	2013.3.27

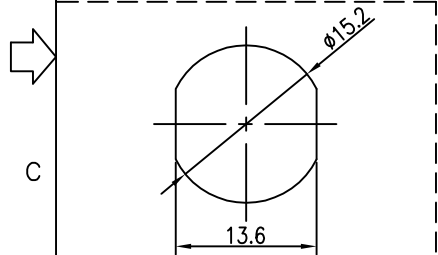

Recommend Panel Cut-out

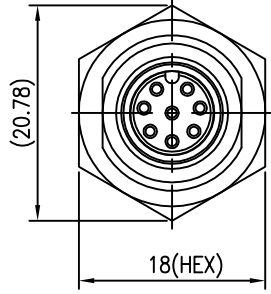
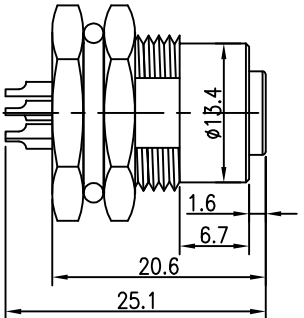
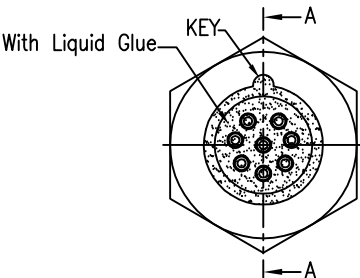
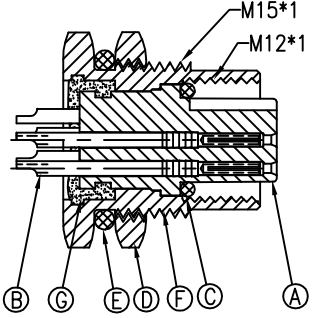

SECTION A-A

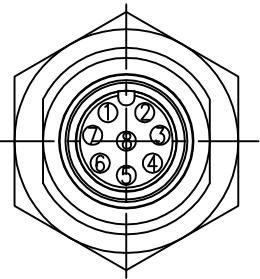

Pin Assignments Front View

- NOTES:
1. WATERPROOF RATE: IP68
IP68: IMMERSED IN 1M WATER FOR 24 HOURS
 2. ELECTRICAL CHARACTERISTICS
TEMPERATURE RANGE: -40°C TO +100°C
RATING: 60V AC/DC 2A
DIELECTRIC WITHSTANDING VOLTAGE: 500V AC FOR ONE MINUTE
 3. SPECIFICATIONS:SEE "M12 SERIES SPECIFICATIONS".
 4. TO CONFORM TO SINGATRON HAZARDOUS SUBSTANCE FREE SPEC.
 5. GREEN PRODUCT IDENTIFICATION LABEL ON PACKAGING: G.P. PASS
 6. FOR PANEL THICKNESS MAX OF 4.0mm

G	LIQUID GLUE	1		BLACK
F	SHIELD	1	BRASS	NICKEL PLATING 100u"
E	O-RING	1	EPDM	BLACK
D	NUT	1	BRASS	NICKEL PLATING 100u"
C	O-RING	1	VITON	RED
B	FEMALE PIN	*	Phosphor Bronze	6u" GOLD PLATING OVER NICKEL PLATING
A	BODY	1	NYLON+33%GF	BLACK
NO	DESCRIPTION	QTY	MATERIAL	PLATING & COLOR

UNLESS OTHERWISE SPECIFIED TOLERANCES		Singatron Electronic(China) Co., Ltd. 信音電子(中國)股份有限公司		
DECIMALS:	ANGLES:	TITLE M12 SERIES FRONT MOUNT FEMALE CONN.(8PIN) HEXAGONAL BACKSHELL		
X :±0.5	X :±2°	DWN	Harlen	PART NO.2MT3002-X08200
X.X :±0.3	X.X :±1°	CHKD	James	SCALE 2:1 UNIT: mm
X.XX :±0.2		APVD	Steve	SIZE: A3 SHEET:1 OF 1 REV: B
CUSTOMER COPY				