

REV.	ECN NO OR DESCRIPTION	REVISED	DATE
A	PDR NO.:	Vicky	2014.07.22

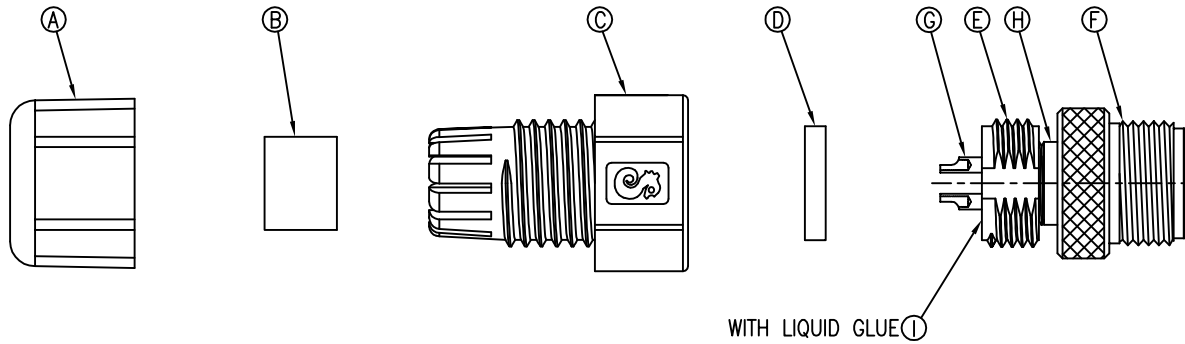

WITH LIQUID GLUE ①

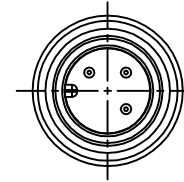
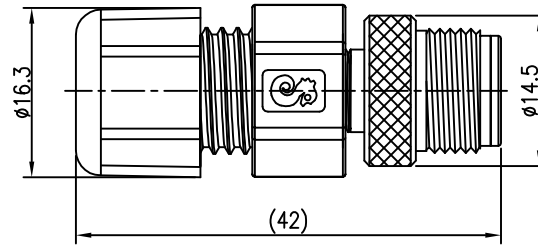

C	2MT3033-X03300H		5A	22AWG~24AWG *3C
B	2MT3033-X04300		5A	22AWG~24AWG *4C
	2MT3033-X05300		5A	22AWG~24AWG *5C
A	2MT3033-X08200H		2A	24AWG~26AWG *8C
	P/N:	Pin Assignments Front View	Current Rating	Recommended Cable AWG

NOTES:

- ELECTRICAL CHARACTERISTICS:
 - 1-1 CONTACT RESISTANCE: 30 mOhm Max.
 - 1-2 INSULATION RESISTANCE: 100 MOhm Min. at 500VDC.
 - 1-3 BREAKDOWN VOLTAGE: 500 VAC PER MINUTE.
- MECHANICAL CHARACTERISTICS:
 - 2-1 TIGHTENING TORQUES: 1.0~1.2Nm(8.85~10.62lbf.in.).
- ENVIRONMENTAL:
 - 3-1 OPERATING TEMPERATURE: -40°C TO +105°C.
 - 3-2 SEALING REQUIREMENTS: IP68.
- OTHER GENERAL SPEC. TO REFER "M12 SERIES SPEC."
- FOR TECHNICAL DATA REFER TO YOUR LOCAL SINGATRON ELECTRONICS SALES OFFICE.
- ALL DIMENSIONS ARE NOMINAL FOR REFERENCE ONLY UNLESS OTHERWISE STATED.
- TO CONFORM TO SINGATRON HAZARDOUS SUBSTANCE FREE SPEC.
- GREEN PRODUCT IDENTIFICATION LABEL ON PACKAGING:

NO	DESCRIPTION	QTY	MATERIAL	PLATING & COLOR
I	LIQUID GLUE	1	N/A	BLACK
H	BODY	1	PA66+GF	BLACK
G	MALE PIN	*	BRASS	6u" GOLD PLATING OVER NICKEL PLATING
F	SCREW NUT	1	BRASS	NICKEL PLATING
E	SCREW NUT	1	PA66+GF	BLACK
D	GASKET	1	SILICONE	BLACK
C	CLAMP RING	1	PC	BLACK
B	SEAL	1	EPDM	BLACK
A	SEALING NUT	1	PC	BLACK
UNLESS OTHERWISE SPECIFIED TOLERANCES				
Singatron Electronic(China) Co., Ltd. 信音電子(中國)股份有限公司				
DECIMALS:		ANGLES:		TITLE
X	:±0.5	X	:±2°	M12 SERIES (IP68) MALE CONN
X.X	:±0.3	X.X	:±1°	MALE 3~8PIN ASSEMBLY TYPE
X.XX	:±0.2			
DWN	Vicky	PART NO.2MT3033-X0XX00		A
CHKD	Shawn	SCALE 2:1	UNIT: mm	
APVD	Quan	SIZE: A3	SHEET:1 OF 1	REV: A
CUSTOMER COPY				