

1 2 3 4 5 6 7 8

REV.	ECN NO OR DESCRIPTION	REVISED	DATE
A	PDR NO.:S110222-4A	Glen	2011.05.25
B	ECN NO.:S150807-R	Vicky	2015.09.07

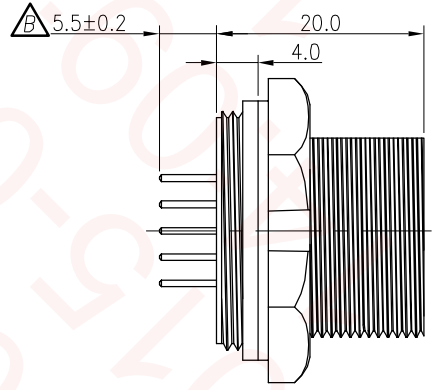
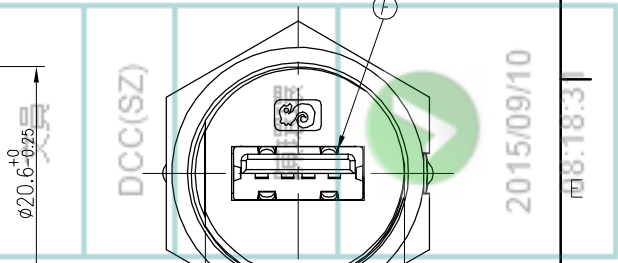
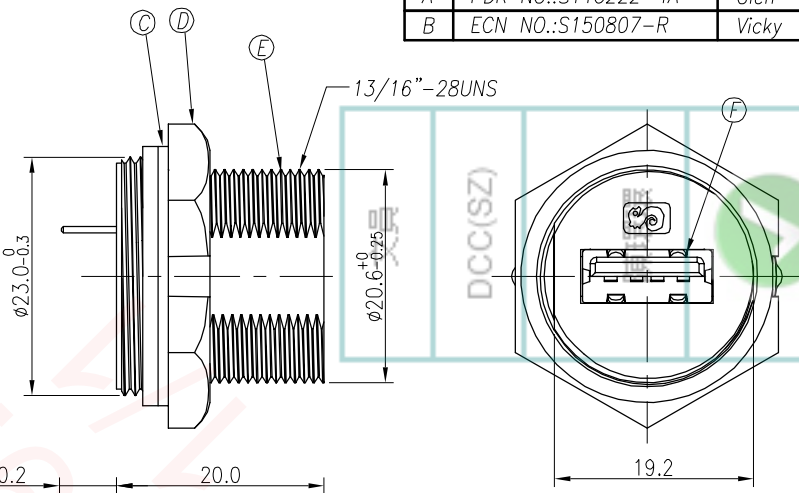
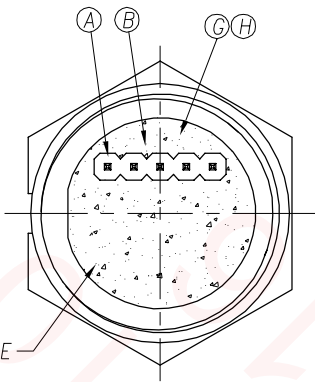
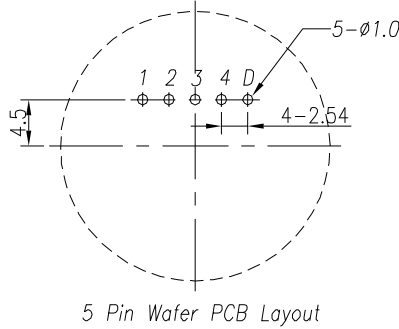

NOTES:

1. WATERPROOF RATE: IP67  
IP67: IMMERSED IN 1M WATER FOR 30 MINUTES
2. ELECTRICAL CHARACTERISTICS:  
1-1. RATING: 30V 1A  
1-2. CONTACT RESISTANCE: 30mΩ MAX.(INITIAL)  
1-3. DIELECTRIC WITHSTANDING VOLTAGE: 500V AC FOR ONE MINUTE  
1-4. INSULATION RESISTANCE: 100MΩ MIN. MEASURED BY 500 VDC
3. OTHER GENERAL SPEC. TO REFER "2UB1518 SERIES SPEC".
4. INSERTION FORCE: 3.5KGF MAX.  
WITHDRAW FORCE: 0.5KGF MIN.
5. TO CONFORM TO SINGATRON HAZARDOUS SUBSTANCE FREE SPEC.
6. GREEN PRODUCT IDENTIFICATION LABEL ON PACKAGING: **G.P. PASS**
7. FOR PANEL THICKNESS MAX OF 4.0mm

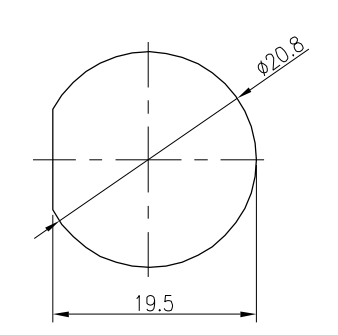
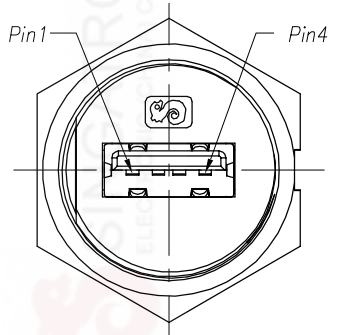

H	UV GLUE	1	N/A	NATURAL
G	LIQUID GLUE	1	N/A	BLACK
F	USB CONN.	1	USB A RECEPTACLE	N/A
E	HOUSING	1	PC	BLACK
D	SCREW NUT	1	PA66	BLACK
C	GASKET	1	EPDM	BLACK
B	PCB	1	FR-4	GREEN
A	WAFER	1	5PIN 2.54PITCH	BLACK
NO	DESCRIPTION	QTY	MATERIAL	PLATING & COLOR

UNLESS OTHERWISE SPECIFIED TOLERANCES		Singatron Enterprise Co., Ltd. 信音企業股份有限公司	
DECIMALS:	ANGLES:	TITLE	WATERPROOF USB 2.0 JACK
X :±0.5	X :±2°	DWN	Vicky PART NO.2UB3001-W05113H
X.X :±0.3	X.X :±1°	CHKD	Harlen SCALE 2:1 UNIT: mm
X.XX :±0.2		APVD	Steve SIZE: A3 SHEET:1 OF 1 REV: B
CUSTOMER COPY			

1 2 3 4 5 6 7 8