

REV.	ECN NO OR DESCRIPTION	REVISED	DATE
A	PRODUCT RELEASE	Weiije.Zeng	19.04.19

SPECIFICATIONS:

- ELECTRICAL CHARACTERISTICS:
 - CONTACT RESISTANCE: 50mΩ MAX.
 - INSULATION RESISTANCE: 100MΩ MIN. BY 500V DC.
 - DIELECTRIC WITHSTANDING VOLTAGE: 500V AC FOR 1 MINUTE.
- MECHANICAL CHARACTERISTICS:
 - INSERTION FORCE: 0.3~3.0Kgf.
 - WITHDRAWAL FORCE: 0.3~3.0Kgf.
- LIFE TEST: 5,000 CYCLES.
- OPERATING TEMPERATURE: -10°C TO +85°C.
- OTHER GENERAL SPEC. TO REFER "2.5φ PHONE JACK SPEC".
- TO CONFORM TO THE SINGATRON HAZARDOUS SUBSTANCE FREE SPEC.
- HALOGEN FREE PRODUCT IDENTIFICATION LABEL ON PACKAGING: 
- FOR REFLOW SOLDERING LEAD-FREE PROCESS.
- PACKAGING: TAPE&REEL

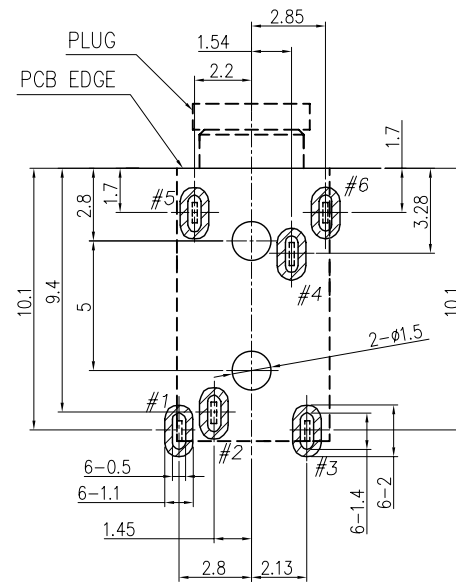
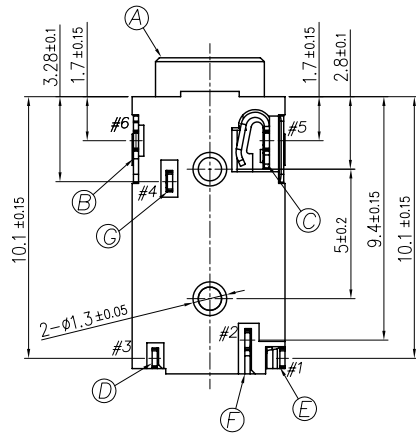
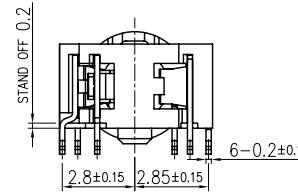
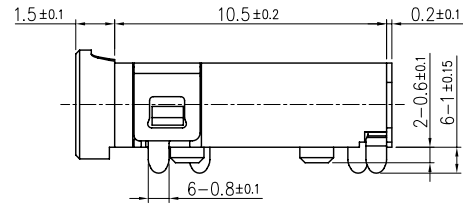
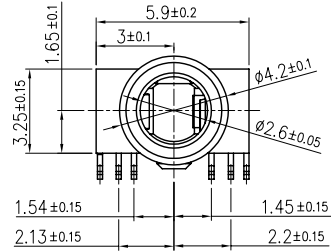

RECOMMENDED PCB LAYOUT T=0.8
TOP VIEW (TOLERANCE: ±0.05)

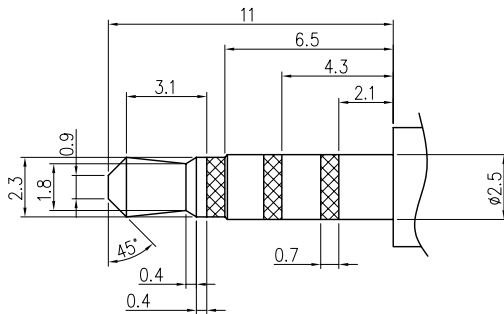
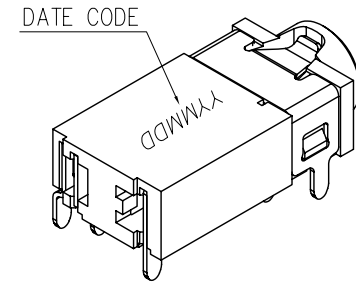
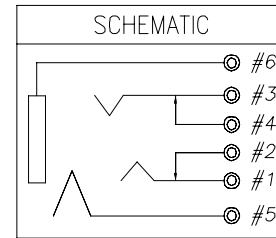

φ2.5 4POLE PLUG(±0.05)

NO	DESCRIPTION	QTY	MATERIAL	PLATING & COLOR
G	SHUNT-2	1	COPPER ALLOY 0.2T	GOLD FLASH
F	SHUNT-1	1	COPPER ALLOY 0.2T	GOLD FLASH
E	TIP SPRING	1	COPPER ALLOY 0.2T	GOLD FLASH
D	RING SPRING-A	1	COPPER ALLOY 0.2T	GOLD FLASH
C	RING SPRING-B	1	COPPER ALLOY 0.2T	GOLD FLASH
B	EARTH TERMINAL	1	COPPER ALLOY 0.2T	GOLD FLASH
A	HOUSING	1	HIGH TEMP PLASTIC	BLACK
UNLESS OTHERWISE SPECIFIED TOLERANCES		 Singatron Enterprise Co., Ltd. 信音企業股份有限公司		
DECIMALS: ANGLES:		TITLE: 2.5φ MINIATURE JACK		
X	:±0.5	X	:±2°	DWN <small>Weiije-Zeng 19/04/22</small> PART NO. 2SJ1624-000121F
X.X	:±0.3	X.X	:±1°	CHKD <small>Qical-Hu 19/04/22</small> SCALE 4:1 UNIT: mm 
X.XX	:±0.2	APVD <small>Jm-deng 19/04/22</small>	SIZE: A3	SHEET: 1 OF 1 REV: A
CUSTOMER COPY				